



Mobile Column

HEAVY DUTY LIFTING SYSTEMS

Dependable Ergonomic **FLEET** Versatile Reliable
Performance Productive **FAST**
 Mobile World **LEADER** Best Techs
 Buy America **RedFire**™ Remote controlled **MACH**™ Legendary
 Battery **Efficient** **HEAVY DUTY**
 Patented ENVIRONMENTALLY FRIENDLY **Wireless** Career Extender
Flex™ Innovative **Employee Retention** Adjustable



www.rotarylif.com



Shown: MCHM419U1A00 / Wireless remote-controlled model

POWERED BY **RedFire**

WIRELESS CONTROLS
NO CABLES / NO CORDS



FLEXMAX419
18,800 lbs. capacity column



Shown: MCHM419U100

Rotary FLEXMAX™ feature column capacities at 18,800 lbs. and 14,000 lbs. in multiple configurations.

Service everything from light-duty passenger vehicles to heavy-duty trucks. This electro-hydraulic system with adjustable lifting forks can be operated in both odd and even groups of columns.

Battery operated with on-board charger - no power cords to clutter up the service bay. 24V DC batteries with 110V charging system. Group of 2. Batteries purchased separately for international use.

Inverted hydraulic cylinder rod located inside the carriage, protects chrome piston rod from debris and damage.

Easy to move adjustable forks improve set up time.

Spring loaded steering and braking system eliminates the need to manually operate the jacks. Automatically prevents movement on sloped floors.

Digital column gauges display vehicle height and weight

Forklift pockets provide convenient way to relocate columns within your shop.

All models are **ALI Gold Certified**

18,800 LBS. COLUMN CAPACITIES
MCHM19 | FLEX MAX™

- Group of 2 columns / 37,600 lbs. Capacity
- Group of 4 columns / 75,200 lbs. Capacity
- Group of 6 columns / 112,800 lbs. Capacity
- Group of 8 columns / 150,400 lbs. Capacity



Rise	70" (1778 mm)
Column width	45.5" (1156 mm)
Wheel Rim Size	9"to 24" (228 to 610 mm)
Clearance / fork to column	10" (254 mm)
Speed of rise	78 seconds
Charging voltage	110v charger* (2.5 amps max.)

FLEXMAX™
REMOTE-CONTROLLED LIFTING

Unmatched lifting versatility and flexibility with the mobility to monitor and adjust your columns anywhere in your shop.

POWERED BY



Premium FLEXMAX™ lifts provide wireless, remote-controlled flexibility plus added operational controls at each column giving technicians the choice to work in the most comfortable, productive and efficient way possible.



Ergonomic, wireless hand-held remote control walks the technician through the system set up. Status lights indicate standby or paired columns.

Controller features include:

- On/off power button with info screen
- 2-speed joystick control with auto resume
- Single lower-to-lock button with E-stop control
- Remote battery indicator
- Press Protect™ eliminates accidental button presses
- Audible warning when operator is out of range
- 99 system IDs eliminate communication interference
- Height and weight digital display gauge displays
- Software upgrades can be made wirelessly



WATCH THE PRODUCT VIDEO
See how fast and easy it is to set up and operate FLEX lifts

FLEXMAX™ single column controls allow user with remote to select and change column groups and cycle lifts from any column. Includes large screen designed for the toughest shop.



Exclusive LOCK LIGHT™ indicates when a column is on its locks



Environmentally-friendly benefits:



- Surface mounted - no excavation or site prep
- Optional LED lighting
- More than 98% recyclable
- Compatible with all bio fluid hydraulic oils

14,000 LBS. COLUMN CAPACITIES
MCHM14 | FLEX MAX™

- Group of 2 columns / 28,000 lbs. Capacity
- Group of 4 columns / 56,000 lbs. Capacity
- Group of 6 columns / 84,000 lbs. Capacity
- Group of 8 columns / 112,000 lbs. Capacity



Rise	69" (1760 mm)
Column width	43" (1092 mm)
Wheel Rim Size	9"to 24" (228 to 610 mm)
Clearance / fork to column	10" (254 mm)
Speed of rise	68 seconds
Charging voltage	110v charger* (2.5 amps max.)

* Call factory for alternate voltage

MCHW18

WIRELESS MACH™ SERIES LIFTS MOBILE LIFTING TECHNOLOGY WITH INTUITIVE CONTROLS AT EACH COLUMN

The MACH SERIES Mobile Column lift system is the faster and easier choice for your maintenance facility. The set-up time and lifting speed beats the competitor hands down with fewer steps required by the technician to put the lift in service.

Industry exclusive intuitive control console
- no master / slave column



WATCH THE PRODUCT VIDEO
Learn more about our industry-leading lift features

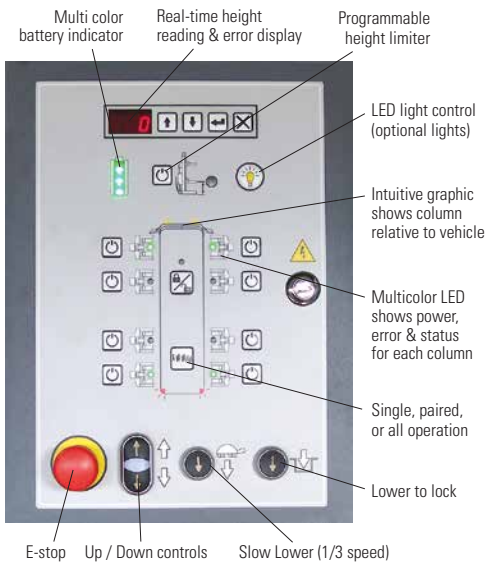

OPTIONAL WIRED / CORDED COLUMN COMMUNICATION

Includes Retractable Cord Reels with Quick Connect Cables

Easy one-handed connectivity between columns, don't waste time handling cables every time you use the lift.

Innovative Horseshoe Wiring

Wired MCH columns use just three cables which form a horseshoe, so the front or back of the lift is always open. Vehicles can be driven in and out of the bay without having to disconnect and reconnect cables saving time with each service.

NOTE: Wired column configuration is a FIELD UPGRADE ONLY.

Consult factory representative for details



Communication Cable

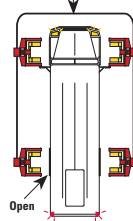

AC POWERED LIFT OPTION

Operate your mobile lifting system without the use of batteries.

- 208/230/460 VAC available
- Sold in groups of 2 and 4 configurations

Consult factory representative for details



WIRELESS CONTROLS
NO CABLES / NO CORDS



MCHW618
18,000 lbs. capacity column

Rotary wireless MACH™ SERIES feature column capacities at 18,000 lbs. in multiple configurations.

Rotary's versatile wireless mobile column lifts give you the option of not being tied to a bay. Easy to use design gives techs the option to control lift from any column.

Take advantage of the power and mobility to make your repairs anywhere in your shop!

Battery operated with on-board charger - no power cords to clutter up the service bay. 24V DC batteries with 110V charging system. Group of 2. Batteries purchased separately for international use.

Inverted hydraulic cylinder rod located inside the carriage, protects chrome piston rod from debris and damage.

Easy to move adjustable forks improve set up time.

Spring loaded steering and braking system eliminates the need to manually operate the jacks. Automatically prevents movement on sloped floors.

Forklift pockets provide convenient way to relocate columns within your shop.

All models are **ALI Gold Certified**

18,000 LBS. COLUMN CAPACITIES MCHW18 | WIRELESS

- Group of 2 columns / 36,000 lbs. Capacity
- Group of 4 columns / 72,000 lbs. Capacity
- Group of 6 columns / 108,000 lbs. Capacity
- Group of 8 columns / 144,000 lbs. Capacity



Rise	70" (1778 mm)
Column width	45.5" (1156 mm)
Wheel Rim Size	9"to 24" (228 to 610 mm)
Clearance / fork to column	10" (254 mm)
Speed of rise	78 seconds
Charging voltage	110v charger* (2.5 amps max.)

* Call factory for alternate voltage

VERSATILE DRIVE-ON CONVERSION

MACH4 PLUS

RUNWAY LIFTING SYSTEMS

36,000 / 60,000 LBS. CAPACITIES

Convert your mobile column series lifts into a heavy duty drive-on lift for vehicle inspection and wheel service.

FEATURES:

Drive on runways accommodate wheelbases up to 33' (396")

Fully hydraulic operation with low electrical usage and controls at all 4 columns

Super fast battery operation. No power? No problem.

Fewer moving parts - no cables or sheaves to maintain equals less maintenance and wear

Internal airlines included for optional rolling jacks and air tools



**For MACH
and Flex Series
Column Lifts**

M140015RD

60,000 lbs. capacity lift



Shown: MCH418U100 with M140015 runway system



Shown: MCH418U100 with M140015 runway system

M140129

36,000 lbs. capacity

For FlexMAX 14
Mobile Columns

Maximum wheel base 30'

M140015

60,000 lbs. capacity

For MCH418 and
FlexMAX 19 Mobile Columns

Maximum wheel base 33'

MACH4 PLUS RUNWAY SYSTEMS

MODELS	M140129CG 414K MOBILE COLUMNS	M140015RD 418K / 419K MOBILE COLUMNS
Lifting Capacity	35,900 lbs. (16,283kg) †	60,000 lbs. (27215kg) ††
Maximum Wheelbase	25' (300"/ 7,620mm)* 30' (360"/ 9,144mm)*	33' (396"/ 10058mm)**
Max. Rise / Floor to top of runway	79" (2,007mm)	78" (1981mm)
Length Overall	33' 11-3/4" (10,358mm) 38' 11-3/4" (11,882mm)	40' 7-1/2" (12382mm)
Width Overall - outside controls	16' 3-3/8" (4963mm)	15' 11" (4851mm)
Height of Columns when raised	89" (2260mm)	144 - 3/4" (3677mm)
Width of Runways	28" (711mm)	28" (711mm)
Drive Thru Between Columns	12'-4" (3607mm)	11'-10" (3607mm)
Runway Spacing	45" (1143mm)	45" (1143mm)
Rise Time	68 seconds	78 seconds
Ramp Angle	7 degrees	10 degrees
Power Usage	Battery powered Charges on 110V	Battery powered Charges on 110V

† WITH FLEX MAX 14 SERIES LIFTS †† WITH MCH18 SERIES and FLEX MAX 19 SERIES LIFTS

*Both 25' and 30' runway length models are available as 35,900 lbs. capacity lifts

**Both 28' and 33' runway length models are available as 60,000 lbs. capacity lifts

OPTIONAL RUNWAY LIFT ACCESSORIES

Rolling Bridge Jacks

Air operated rolling bridge jacks can be attached to the runways creating additional lifting options for greater versatility.

FOR 36,000 lbs. CAPACITY LIFTS

RJ14ABK / 14,000 lbs (6350kg) with lock

RJ22ABK / 22,000 lbs (9979kg) with lock

FOR 60,000 lbs. CAPACITY LIFTS

RJ25BK / 25,000 lbs (11363 kg) with lock



Air operated rolling bridge jacks

Air Operated Tire and Wheel Lifts

Offers maximum maneuverability and adjustable lifting and lowering speeds. Provides technicians with responsive and easy positioning of the tire and wheel, easy alignment of the wheel and hub and a quick transfer to the wheel balancer. Includes air hose and auxiliary air tool connection.

MW-200 / 200 lbs. capacity

MW-500 / 500 lbs. capacity



MW-200

MW-500

Portable Maintenance Jack Stands

RS20YL / Screw-Type Adjustable

56.1"-82.3" / 20,000 lbs. Capacity

RS20WYL / Welded Version of RS20YL

RS2052SYL / Screw-Type Adjustable

34.3 "-55.5" / 20,000 lbs. Capacity

RS36SYL / Screw-Type Adjustable

55.31"-82.28" / 36,000 lbs. Capacity



All jack stands meet the required ASME PASE-2014 safety requirements for portable service equipment.



Always use safety stands when installing or removing heavy components.

LED Runway Lighting Kit

FA5700 / TECH LIGHT™ Line Light 4



Attach the four 54" light wands to runways for effective, efficient lighting where you need it.

Lighting unit includes

60W power supply unit

16' cable lengths

8 magnetic suspensions

120V AC input voltage at 60Hz

Drive-Thru Ramp Kit

M140099RD / 10' Ramps

Adding a drive-thru ramp kit creates a quick and easy on-off service operation for service bays.



FORE and AFT END LIFT KIT
M140168YL
FRAME-ENGAGING / WHEELS-FREE
18,000 LBS. CAPACITIES

MULTI-FUNCTION LIFT KIT
 Features the widest reach in the industry at 43". For use with two MCHW18, MCHM14 or MCHM19 mobile columns on full frame vehicles

Kit comes standard with 3.5", 5", and 10" adapter extensions for greater reach.



Wheels-free, frame-engaging end lift kits enable lifting by the front and rear of the vehicle using stacking adapters.



Shown: MCH418U100 with M140168 frame lift kit
 18,000 lbs. capacity lift

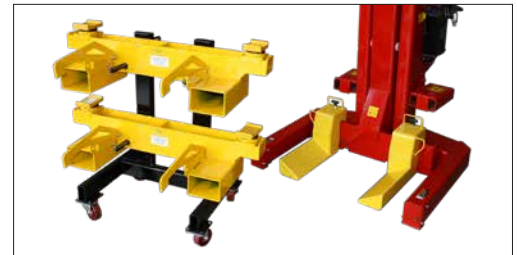

M110108BK
 Optional storage cart for lifting kit

M130242
 Ball Hitch Adapter for use with M140168YL

M120651
 Wide center adapter for use with M140168YL



SERVICE TWO VEHICLES AT ONCE USING A SINGLE SET OF 4 COLUMNS

FORE / AFT END LIFT KIT #M140168

SPECIFICATIONS	
Column Configuration	2 columns
Capacity per set	18,000 lbs.
Rise	69"
Fork to column clearance	10" (254 mm)
Adapter reach	12" Narrow Position 43 1/2" Widest Position 9 1/2" Lowest Pickup Height
Speed of rise	78 seconds / 68 seconds

FRAME-ENGAGING CROSS BEAM KITS

21,000 TO 32,000 LBS. CAPACITIES

Pick up buses, RVs and more with wheels-free, frame-engaging cross beam kits. Beam vehicle spotting allows technicians to service wheels and tires with ease.

All kits are designed for use with MCHW418 or MCHM419 Series lifts.

WARNING:
Never exceed rated capacity.
Refer to operating instructions supplied with lift for proper lifting procedures.

Operate mobile column lifts to desired height.
Always use safety stands as needed or when installing or removing heavy components.



CAUTION:

Never use a bent or damaged crossbeam. Always have an authorized installer make any repairs or replacements. Crossbeams are not to be used as wheel engagement lifts. Do not change or modify the crossbeam in any manner.

LOW PROFILE M140070YL

30,000 lbs Capacity at maximum 49" adapter spread
21,000 lbs. Capacity at minimum 25" adapter spread

Kit includes single cross beam and two (2) support blocks per beam

Adapters need to be equally spaced off each lift and frame should be centered between lifts to help prevent offset loading. Ensure adapters have proper frame engagement.



Shown: M140070 low profile cross beam with optional jack stands

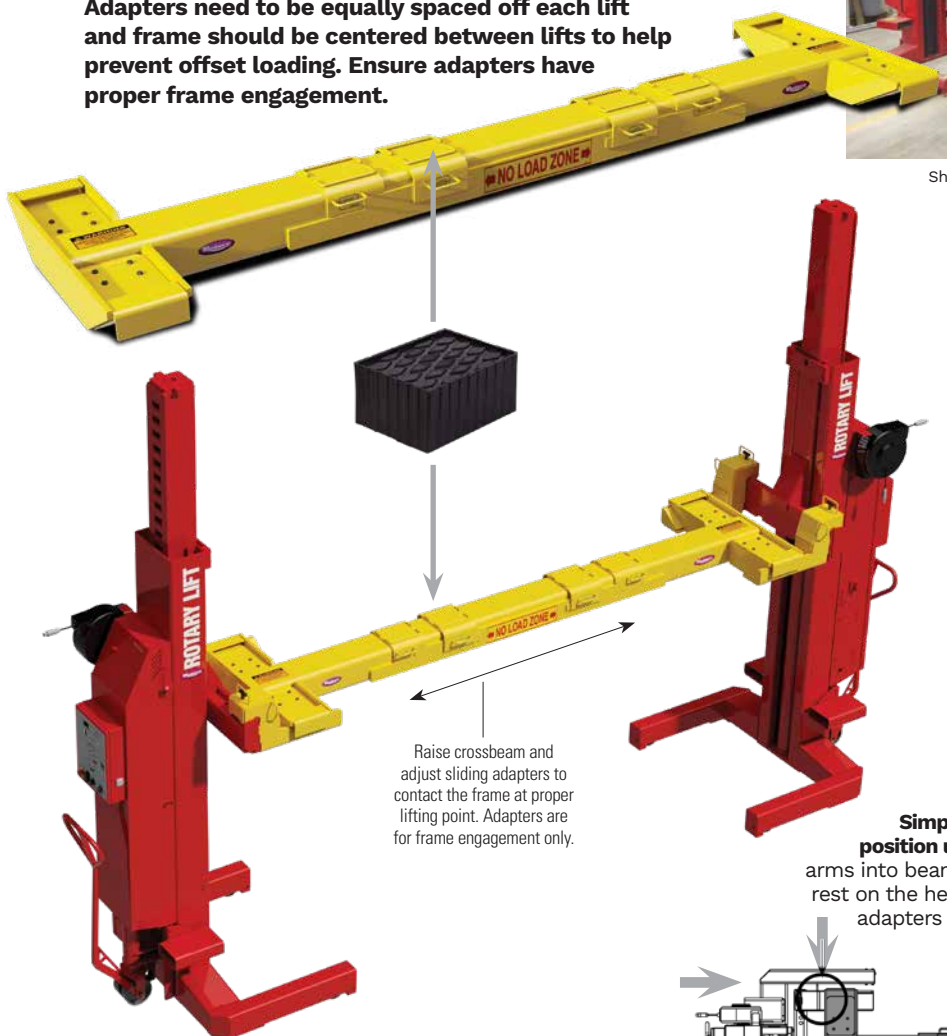

Raise crossbeam and adjust sliding adapters to contact the frame at proper lifting point. Adapters are for frame engagement only.

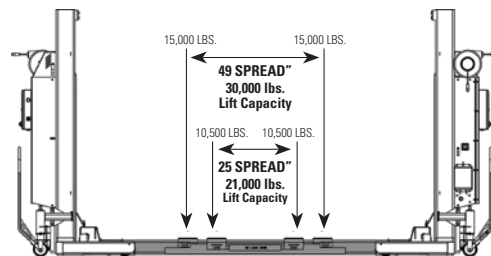

CAPACITIES

30,000 lbs. at 49" adapter spread / 15,000 LBS. per adapter
21,000 lbs. at 25" adapter spread / 10,500 LBS. per adapter
ALI THIRD-PARTY GOLD CERTIFIED

Simply push crossbeam lift adapter into desired position under vehicle. Push the mobile column fork arms into beam ends completely until ends of crossbeam rest on the heel of the forks. Raise crossbeam and adjust adapters to contact the frame at proper lifting point.

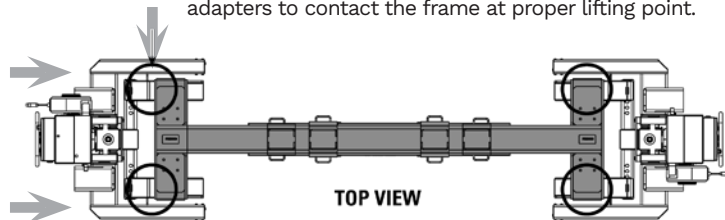

Shown: MCH418U100 with M140070YL cross-beam kit

SADDLE BEAM ML41YL

32,000 lbs Capacity at maximum 72" adapter spread
24,000 lbs. Capacity at minimum 49" adapter spread

Kit includes single cross beam, 2 pairs of frame-engaging adapters, two 5" and two 8" aluminum adapter extensions

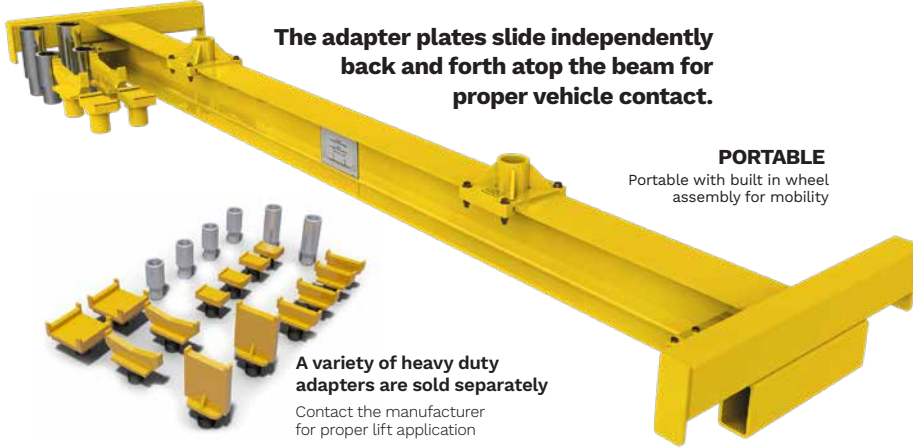

The adapter plates slide independently back and forth atop the beam for proper vehicle contact.

PORTABLE

Portable with built in wheel assembly for mobility

A variety of heavy duty adapters are sold separately
 Contact the manufacturer for proper lift application

Raise crossbeam and adjust sliding adapters to contact the frame at proper lifting point.
 Adapters are for frame engagement only.

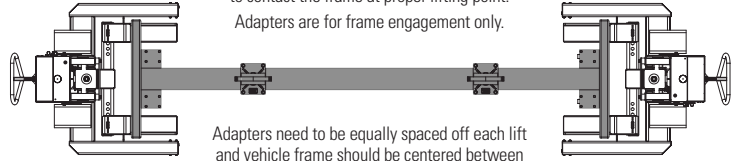

Adapters need to be equally spaced off each lift and vehicle frame should be centered between lifts to help prevent offset loading. Always ensure adapters have proper frame engagement.

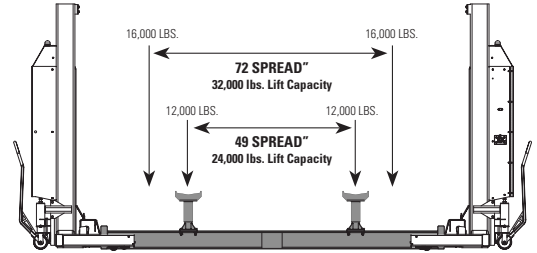

CAPACITIES

32,000 lbs. at 72" adapter spread / 16,000 LBS. per adapter
 24,000 lbs. at 49" adapter spread / 12,000 LBS. per adapter
ALI THIRD-PARTY GOLD CERTIFIED

DRIVE-ON RAMP STYLE KITS

EXTRA WIDE

FD2448KITYL

28,000 lbs Capacity / 154" DRIVE-THRU WIDTH

DRIVE-ON, 26" WIDE RAMPS WITH WHEEL CHOCKS

RAMP STYLE KIT DESIGNED TO SERVICE SNOW REMOVAL TRUCKS WITH WINGPLOWS

Kit includes single cross beam with tow handle

SHOWN: FD2448

EXTRA WIDE DRIVE ON CROSS BEAM KIT with TOW HANDLE



PORTABLE

Built in wheel assembly for mobility

Simple, easy to use drive-on systems

Pull crossbeam adapter into desired position.

Push lift columns under adapter ends and push each in as far as you can.



EXTRA WIDE
154" DRIVE THRU

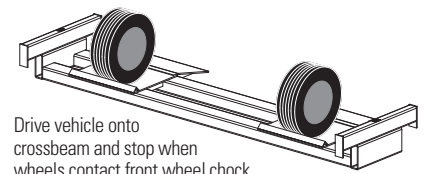

Drive vehicle onto crossbeam and stop when wheels contact front wheel chock.

RAMP STYLE BEAM

FD2353KITYL

22,000 lbs Capacity / 130" DRIVE-THRU WIDTH

DRIVE-ON, 26" WIDE RAMPS WITH WHEEL CHOCKS

RAMP STYLE KIT DESIGNED FOR RV PICK-UP

Kit includes single cross beam

OPTIONAL LIFT ACCESSORIES

Contact the manufacturer for proper lift application

M140112 / Locklight™ Safety Light / MCH Kit

Light indicates when lift is set on its locks
Compatible/retrofitable with DC versions of MCHW columns



M140112

M140115 / Locklight™ Safety Light / MCH Kit

Light indicates when lift is set on its locks
For AC mobile columns and MCHW columns with pre-installed pressure gauges

M140171BK / 24V DC LED Service Lamp Kit

Operates on column's battery power. Includes 2 lamps.
Lights ensure workspace around the lift is well illuminated increasing safety



M140171BK

M140001RD / Long Fork Kit / For recessed wheels

Each kit includes two 22" forks and two 8" leg extensions.
Reduces capacity of column to 12,000 lbs.
For 18K MCH and 19K Flex MAX Models



M140001RD

M140041RD / Long Fork Kit / For recessed wheels

Each kit includes two 20" forks and two 8" leg extensions.
Reduces capacity of column to 14,500 lbs.
For 18K MCHW and 19K Flex MAX Models

M120304BK / Large wheel adapter (per column)

Adapter allows lifting of vehicles with extremely large diameter wheels.



M120304BK

M140157 / Analog Weight Gauge Kit

For MCHW / RCH Series Lifts

M140150 / Pallet Jack Assembly

Available on 19k MCHM lift columns. Black only

M140003 / Pendant Control

For MCHW Mobile Column Lift System - With 33' cable

M140014 / Service Chip for standard wired and wireless MCHW lifts

M140144 / Service Chip for FLEX MAX columns only

AC100005 / Rotary programming tool for heavy duty lifts

Software for laptop running Windows XP/7/8/10 (Laptop not included)

M140024 / Wireless Upgrade Kit

Upgrades a single column for older column kits
Not available on RCH18 or MCH13 lifts



M140157

Rotary Lift

2700 Lanier Drive / Madison, IN 47250, USA

rotarylif.com     

Sales:

1.812.273.1622 / 800.640.5438
userlink@rotarylif.com

Tech. Support:

800.445.5438
techlink@rotarylif.com

Government Sales: 800.445.5438 X5655



For additional information:

rotarylif.com/Government-Purchasing-Assistance/

Benefits of Mobile Columns

To put it simply, mobile columns make life easier for you and your technicians.

Want more?

See what our customers have to say.

"We wanted a product that was worth the cost and easy to use and supported our core value of safety. What we found with the Rotary lift system is that it helped reduce the number of knee injuries, back injuries and hand injuries."

- James Enright
Regional Maintenance Director Schneider National

"After extensive testing of multiple mobile column lifts, I chose Rotary mobile lifts as having the most advanced design, most options and ease of relocating being the best choice for the city. After receiving the lifts, Rotary's customer service and local distributor experience was exceptional."

- Daniel S. Corbin
Fleet Operations Manager
Summerville, South Carolina

"The thing that really stood out for us was the remote control. We did not see that anyone else would offer that, I think that its definitely helped us be more efficient. Would I recommend Rotary's FLEX series mobile columns? I absolutely would. The quality is there. The service is there. The parts are available and they're an American company."

- Mitch Corwin
Transportation Supervisor
New Albany Floyd County Consolidated School System, New Albany, IN

"Rotary has been a Godsend to us because the main thing is we get vehicles repaired and back on the road quicker. Our down list that we get every day has shrunk to a quarter of the size that is used to be...it makes a huge, huge difference."

- George Jacobs
President, Windy City Limousine and Bus
Chicago, IL

Choose the right lift for your shop.

Rotary Lift.



SCAN FOR
MOBILE
COLUMN
INFO

Lit# MOBILE SERIES Brochure_2021.05

©2021 VEHICLE SERVICE GROUP™, Printed in U.S.A., All Rights Reserved. Unless otherwise indicated, ROTARY LIFT, VEHICLE SERVICE GROUP™, DOVER and all other trademarks are property of Dover Corporation and its affiliates.

Manufactured using the following patents:
US Patent No. 6983196 / US Patent No. 8083034

